

FENTON

InnovateElevate

26 Center St. Randolph NY, 14772



Installation and User Guide

THESE PRODUCTS ARE COVERED UNDER ONE OR MORE OF THE FOLLOWING US PATENT NUMBERS
9,550,436 / 9,610,861 / 10,625,867

Table of Contents

Tools and Materials Needed	3
Kits and Spacing Information	4
Kits:	4
Spacing:	5
OEM Seat Base Removal	6
Seat Base Installation	7
Leg with latch:	7
OEM Seat Final Assembly:	8
Freedman Seat Final Assembly:	9
Anti-Rattle	11
User Guide	12



InnovateElevate

26 Center St. Randolph NY, 14772

Tools and Materials Needed

- For bolts:

Single Seat	Double Seat	Triple Seat	Freedman Single	Freedman Double
9/16" socket	5/16", 9/16"	5/16", 9/16"	3/4" open wrench	5/16", 1/2" open wrench

- Crescent wrench
- Necessary parts and accessories:

Single Seat	1 CAM2 leg, w/ latch 1 CAM2 leg, no latch	Hardware kit
Double Seat	2 CAM2 legs, w/ latches	Hardware kit Cross brace tube – <u>CLZWTLCB</u> Rear spacer web – <u>CLZWTLRS</u> Front spacer tab – <u>CLZWTLFS</u>
Triple Seat	2 CAM2 legs, w/ latches 1 CAM2 leg, no latch	Hardware kit Rear spacer web – <u>CLZWTLRS</u> Front spacer tab – <u>CLZWTLFS</u>
Freedman Single	1 CAM2 leg, w/ latch 1 CAM2 leg, no latch	Hardware kit
Freedman Double	2 CAM2 legs, w/ latches 1 CAM2 leg, no latch	Hardware kit Cross brace tube – <u>CLZWTLCB</u>



InnovateElevate
26 Center St. Randolph NY, 14772

Kits and Spacing Information

Kits:

Kit Number	OEM PN	Passengers	Class	Row	Width
CL2ATSS021	1012021	10 Passenger	120 Class	2	Single (Passenger)
	1214021	12 Passenger	140 Class		
	1514021	15 Passenger			
	1517021				
	1017021	10 Passenger	170 Class		
	1417021	14 Passenger			
CL2ATD02DP	1012012	10 Passenger	120 Class	1	Double Wide (Driver)
	1012022			2	
	1214022	12 Passenger	140 Class	2	
	1414012	14 Passenger		1	
	1414022			2	
	1414032			3	
	1514022			15 Passenger	
	1514032	3			
	1017012	10 Passenger	170 Class	1	
	1017022			2	
	1017032			3	
	1417012	14 Passenger		1	
	1417022			2	
	1417032			3	
	1517022	15 Passenger	2		
	1517032		3		
CL2ATDN2DP	1214032D	12 Passenger	140 Class	3	Double Narrow (Driver)
	1214032P				Double Narrow (Passenger)
	1417042P	14 Passenger	170 Class	4	Double Narrow (Driver)
	1417042D				Double Narrow (Passenger)
	1517042D	15 Passenger		4	Double Narrow (Driver)
	1517042P				Double Narrow (Passenger)
CL2ATD02CN	1414042	14 Passenger	140 Class	4	Double Narrow (Center)
	1514042	15 Passenger			



InnovateElevate

26 Center St. Randolph NY, 14772

Kit Number	OEM PN	Passengers	Class	Row	Width
CL2ATTN013	812013	8 Passenger	120 Class	1	Triple Narrow (Driver)
	814013		140 Class		
	1214013	12 Passenger			
	1514013	15 Passenger			
	1517013		170 Class		
CL2ATTW2333	512013	5 Passenger	120 Class	1	Triple Wide (Driver)
	812023	8 Passenger		2	
	1012033	10 Passenger		3	
	814023	8 Passenger		140 Class	

Spacing:

Single Seat	Double Seat	Triple Seat	Freedman Single	Freedman Double
6 1/4"	18 3/4"	12 1/2", 6 1/4"	6 1/4"	18 3/4"



InnovateElevate

26 Center St. Randolph NY, 14772

OEM Seat Base Removal

To convert your OEM seat into an AbiliTrax-compatible, moveable CAMLock2 seat, the old seat base must first be removed.

To remove OEM seat base, use a 5/8" socket—or an adjustable crescent wrench—to remove the OEM bolts and remove the legs.



Seat Base Installation

Leg with latch:

To assemble the latch, **thread** the lever through the slot and get it into position as shown. While the lever is still moving freely, **attach** the spring **[11/12]**. **Put** the bolt through the spacer. Now, **stretch** the spring to align the hole in the lever with the hole on the seat leg, and **thread** the bolt, with the spacer, through the holes. **Apply** some *Vibra-TITE* threadlocker and **secure** the lever with the flange nut **[1]**.

The leg with the “ALIGN GREEN TO LOCK” sticker on the lever handle is installed on the passenger side. The “UNLOCKED/LOCKED” sticker is on the front of the leg. The green section of the sticker **MUST** align with the green sticker on the lever handle when the lever is pressed **ALL THE WAY DOWN** **[2]**.



OEM Seat Final Assembly:

To attach the CAMLock2 seat legs to the OEM seat, **follow** the spacing guidance on page 3 and the exploded parts view for the correct seat style on page 8. **Thread** each bolt through a lock washer, a flat washer, the seat base bracket, the CAMLock2 leg, and a nut, in that order (with one exception for CL2ATD02DP: one of the legs is on the other side of the seat base bracket, according to the diagram).



Additionally, **tighten** the two nuts and bolts on the front face of each leg.

Use the remaining hardware to **install** any additional cross-members included in your build.



Freedman Seat Final Assembly:

To install the CAMLock2 seat legs to a Freedman seat, first **ensure** that the proper part numbers are ordered from Freedman. Freedman supplies special variations of their seats for AbiliTrax retro-fit, and can be identified by the suffix “-ABLTX” in their part numbers. With this kit, **place** the spring T-nuts [7] inside the front crossmember. In the rear crossmember, **place** the plates inside, then **place** the spring T-nut inside the



crossmember on top of the plate, lining up the holes. **Space** the legs [8] according to the table on Page 5. **Put** the lock washer, then flat washer on a bolt, then **put** the bolt through the front hole in the top of the seat leg/base, and **tighten** it into a T-nut in the front crossmember. Next, **put** the lock washer, then two flat washers on a bolt, then **put** the bolt through the rear hole in the top of the seat leg/base, up through the plate, and **tighten** it into a T-nut in the rear crossmember [9/10]. **Repeat** for each leg.

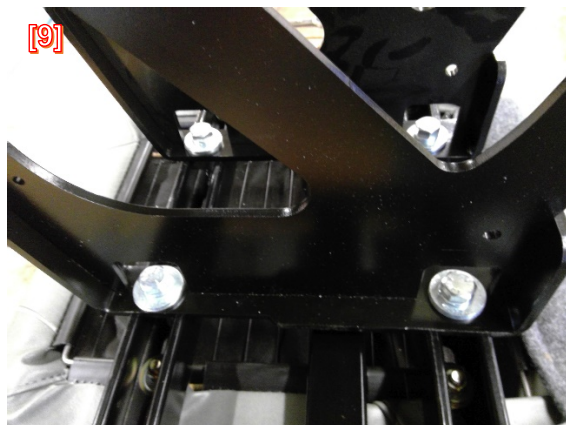

CL2ATSS021

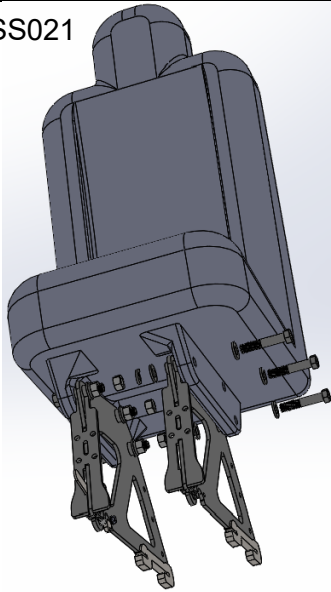

CL2ATD02DP

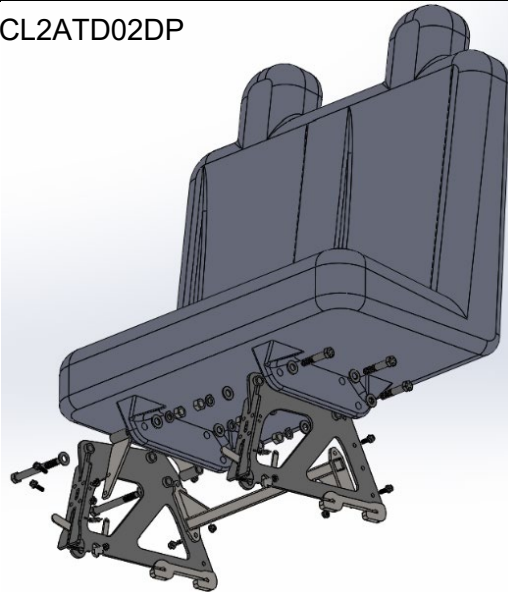

CL2ATDN2DP

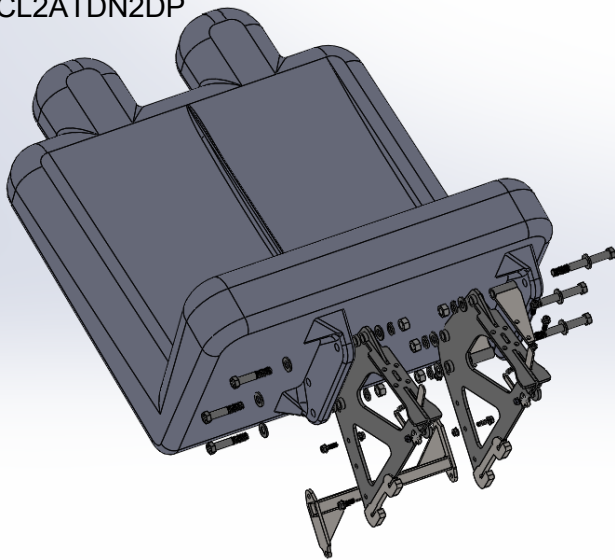

CL2ATD02CN

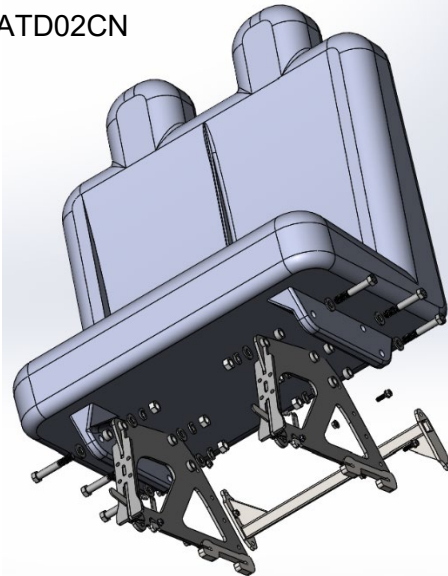

CL2ATTN013

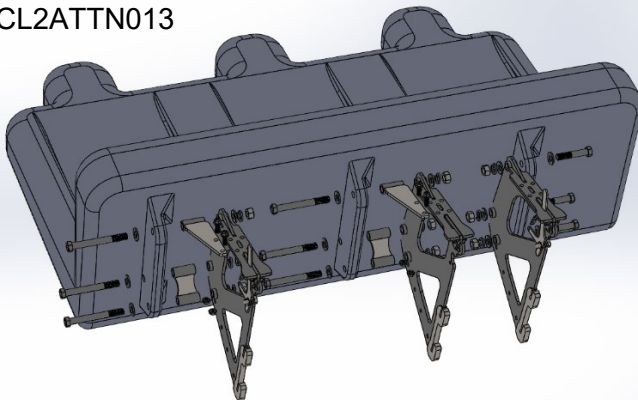

CL2ATTW2333

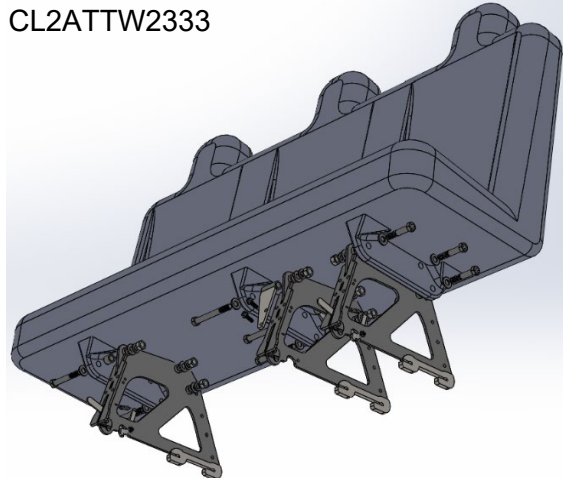

CAM2LOCK Anti-Rattle

AbiliTrax floor systems are designed to maintain consistent spacing and sizing with very little tolerance. Nevertheless, certain imperfections due to vehicle shape and rail curvature are inevitable. To minimize play in the latches and prevent rattling, two plastic anti-rattle spacer pieces are included for the build.

Attach the anti-rattle spacers symmetrically on either side of the seat leg and **secure** with the provided bolt and flange nut [11/12].

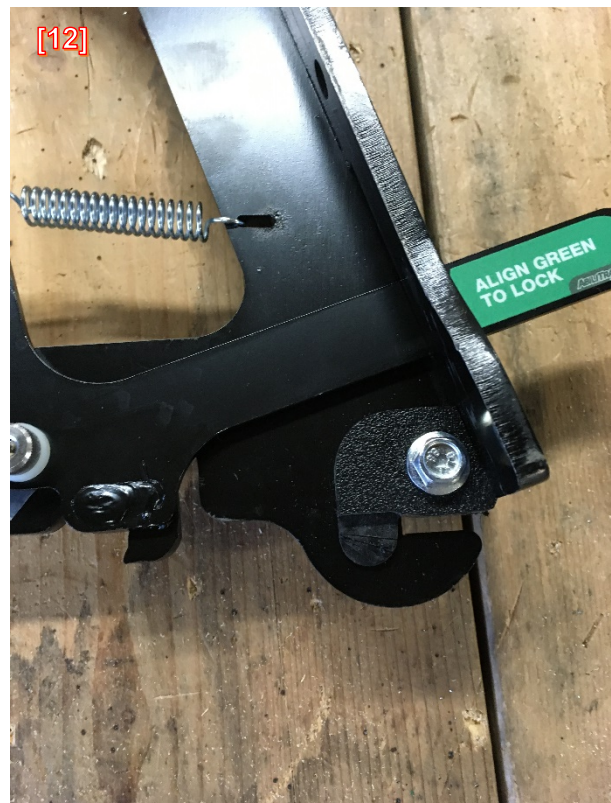

CAM2LOCK User Guide

For use with Fenton's AbiliTrax flooring system

CAMLock2 allows Factory OEM Seat integration with an FMVSS seat base solution, dramatically reducing the cost for up-fitting vans that require passenger seating.

Latching System allows for install, repositioning, and/or complete removal without the use of tools.

To move the seat, **lift** up on the Lock Lever(s) to **release** the CAM(s). Then, **push** the assembly backward, toward the rear of the vehicle.

Once the seat has moved back a little, the CAM(s) and latch hook(s) should basically be free from the AbiliTrax. **Tilt** the seat assembly forward to lift it up and out of the AbiliTrax (two people may be required for the lift).

Move the seat to the new desired location (free of obstructions), **select** your track, and

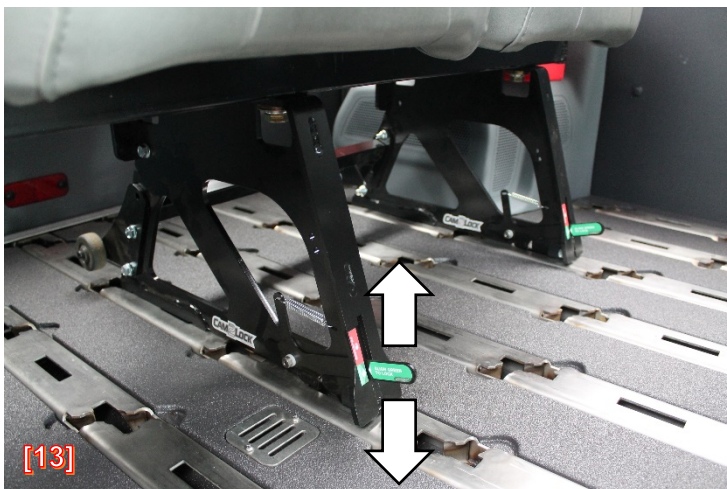

lower the Latch Hook(s) into the AbiliTrax floor **[13]**. **Push** the assembly forward with bodyweight until they are fully forward and the Lock Lever(s) can be fully **engaged**.

